



BubbleWrap®
BRAND PACKAGING

Flex

Inflatable Cushioning System

Versatile, inflatable cushioning, fast enough to keep up with the most demanding packaging operation



INCREASED THROUGHPUT

The BUBBLE WRAP® brand Flex inflatable cushioning system produces materials at speeds up to 27m per minute.

Maximum and fast inflation of packaging material with the build in compressor makes manufacturing more productive, operators more efficient and delivers more products out the door on time. Throughput is increased as well thanks to long film rolls.

HIGH RELIABILITY

Delays in production can slow down productivity. Limit the potential for throughput loss with the Flex inflatable cushioning system. Components are manufactured with high performance materials and coatings for long life system reliability.

SYSTEM ACCESSORIES FOR EVERY CONFIGURATION

The Flex is supported by a range of accessories to increase the throughput including:

- System stand and roll winder, bins and dispensers for decentralised packaging environments
- Instasheeter™ converting system
- Jet Stream Fit® delivery system

INCREASED CUSTOMER EXPERIENCE

Attractive, protective, intuitive packages that can be readily reused or recycled*.

Multiple film patterns and bubble sizes designed for the right size solution, reducing material usage and improving the packaging process.

THE DIFFERENCE IS IN THE BARRIER

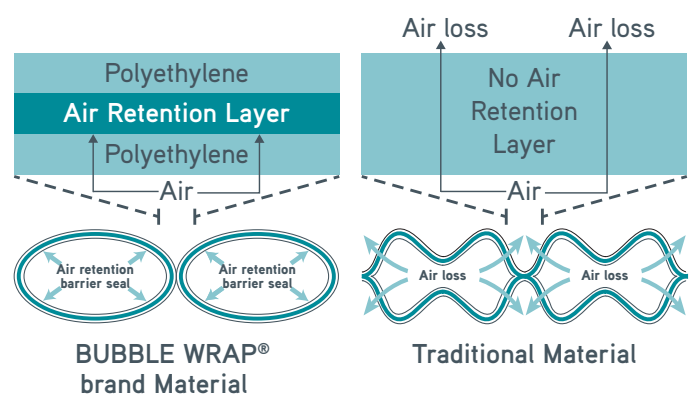

**Degree of recyclability will vary depending on scope and availability of flexible film collection, sortation and recycling programs.*





SUSTAINABILITY

MAXIMUM INFLATION REDUCES EXCESS MATERIAL AND REDUCES DAMAGE

The system runs with an exclusive range of film solutions. By optimising the right film type for the right application, it is possible to benefit from material reduction.

A broad material portfolio matches to the system. The material optimises the shipping cycle and outer box size while improving operational efficiency and reducing costs.

Our patented Barrier Bubble Technology retains the air during the shipping cycle and warehousing. It provides superior cushioning performance compared to traditional materials, reducing damage.

The films are compatible with mechanical recycling streams of LDPE and recyclable in many locations. *Degree of recyclability will vary depending on scope and availability of flexible film collection, sortation and recycling programs.*

SPECIFICATIONS

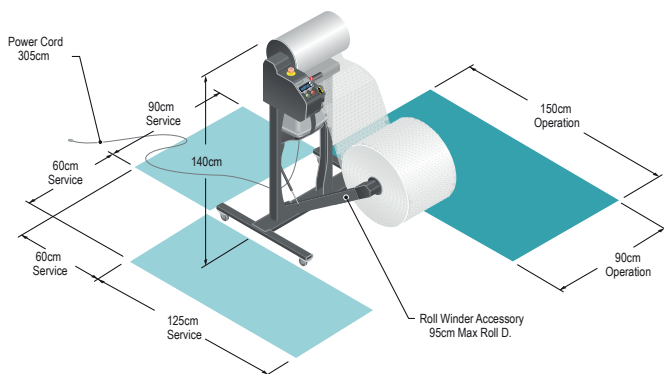

System Set-up - Stand with Roll Winder Version

Electrical:
220/240 VAC 50/60 Hz 2A,
Single Phase

Weight:
System Only 29kg
System + Stand 51kg
System + Stand + Winder 59kg

Overall Size (L x W x H):
74cm x 66cm x 48cm



TYPICAL APPLICATIONS

The BUBBLE WRAP® brand films offer the protective packaging needs from light weight cushioning and wrapping, up to heavy weight cushioning in a variety of markets.



Automotive



3PL

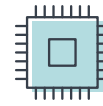

Electronic



Home Goods



Medical Equipment



Cosmetics



E-Commerce Packaging



Aerospace

