

NASTRO-SB™ - R8

The Next Benchmark

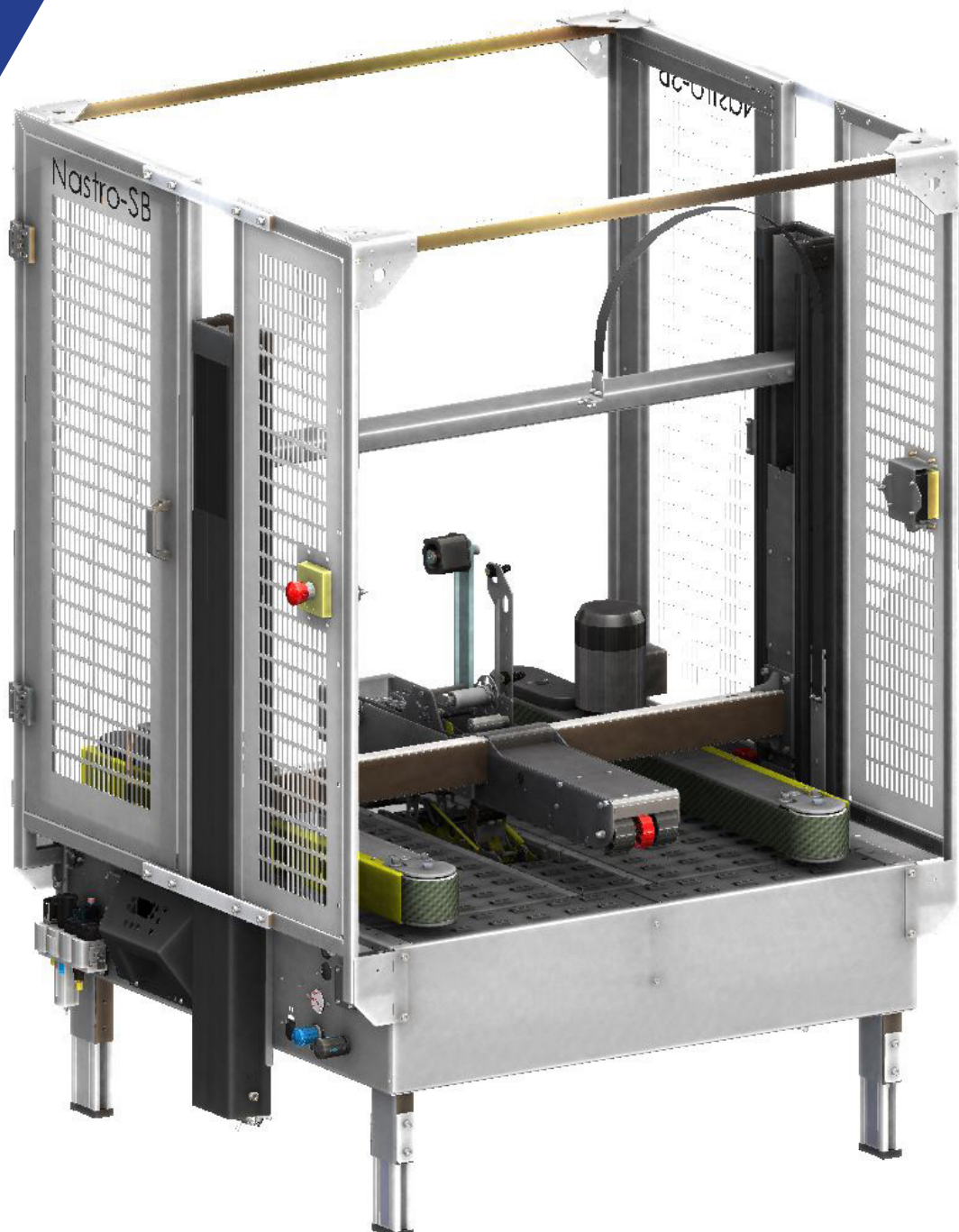

NASTRO-SB™ - R8

Nastro-SB™ R8 is a range of semi-automatic case sealing machines designed and engineered by SIAT specifically for king random boxes with logic on board. Nastro-SB™ R8 is the ideal case sealing machine for a variety of industries like food&beverage, chemical, clothes and e-commerce.

SPECIFICATIONS

Max Production Capacity: 750 boxes/hour

Case type: RSC - FEFCO 0201

Max case weight: 32 kg

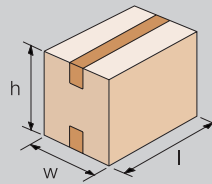

| Box dimensions | L (mm) | W (mm) | H (mm) |
|----------------|---------|-----------|-----------|
| R8B-S / R8T-S | 150 - ∞ | 150 - 800 | 90* - 800 |
| R8B-L / R8T-L | 150 - ∞ | 105 - 800 | 50* - 800 |

* with 30 mm tape leg

KEY FEATURES

- » Lockable power and air supply switch
- » Double side emergency buttons
- » Removable heads without tools
- » 75 mm high belt conveyor
- » Easy to replace belt without removing the conveyor
- » 50 mm minimum box height (with L version)
- » Best-in-class pneumatic components
- » Linear belt conveyor movement
- » It can be equipped with IoT System
- » Faster than standard case sealers thanks to patented variable speed functions

ENERGY SAVING

Motors and conveyors stop after a defined time when no cartons are detected

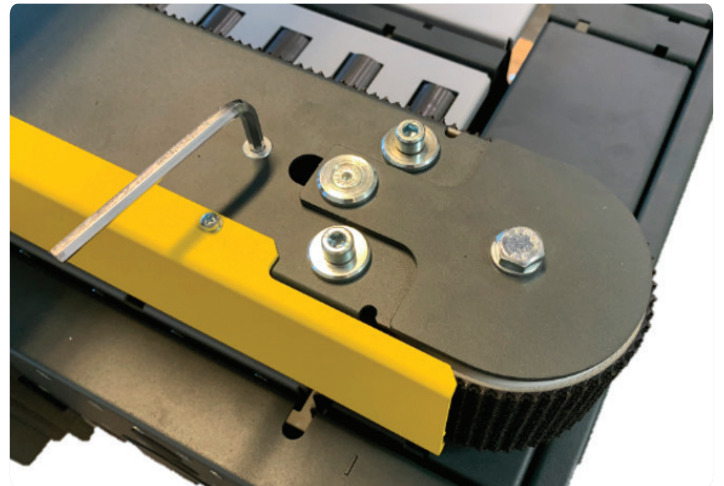

Safety fences with access door

top taping unit

Emergency button on both sides

Easy to maintain belt conveyor

New high performance control panel

Top head and belt conveyor pressure regulation mobs

Bottom taping unit

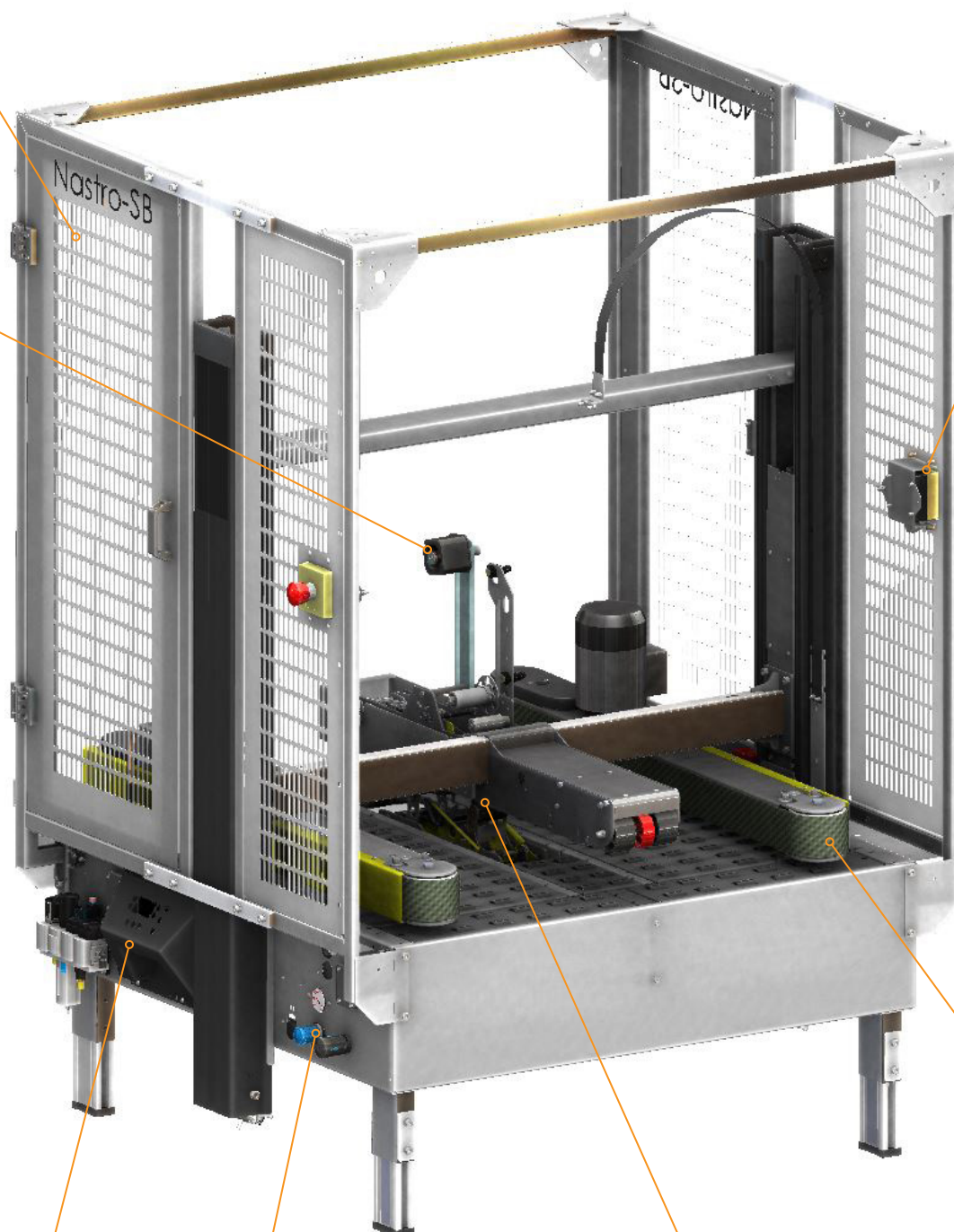

NASTRO-SB™ - R8

Machine dimensions

Dimensioni macchina
Maschinenabmessungen
Dimensions machine
Dimensiones de máquina

| | Model | Min (mm) | Max (mm) |
|---------|-------|----------|----------|
| Total H | R8 | 1835 | 2095 |
| H Bench | ALL | 540 | 800 |
| W | R8 | 1395 | 1395 |
| L | ALL | 1100 | 1100 |

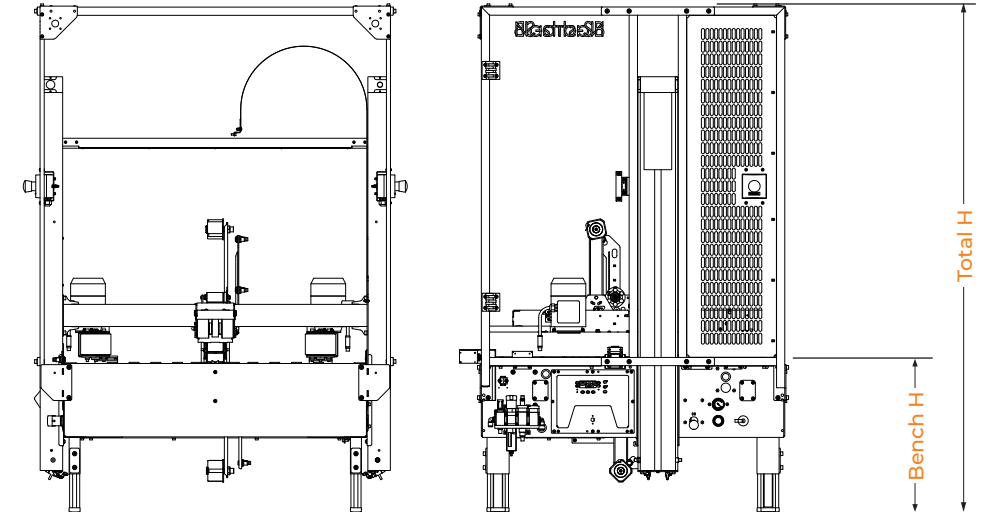

www.hangar2.it

Max Production capacity

Capacità di produzione
Produktionskapazität
Capacité de production
Capacidad de producción

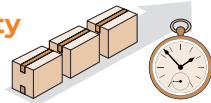

up to 800 Bph

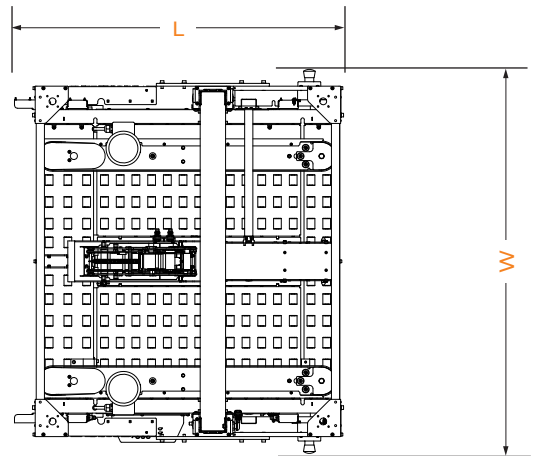

Standard power supply

Alimentazione standard
Standard-Stromanschluß
Alimentation électrique standard
Fuente de alimentación estándar

| | |
|----------------------------|--------------|
| 220/240V - 50/60Hz - 1PH+N | |
| or 440V - 50/60Hz - 3PH+N | |
| Amps | 3,4 |
| Power kW | 0,5 |
| Phase | 1Ph + N + PE |

Optional Extras

Accessori
Zubehör
Accessories
Accesorios

GTL - GTR

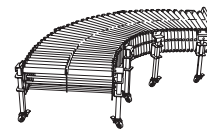

Higher Legs



AS77

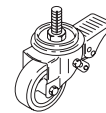

RG

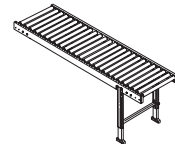

Nastro legs low height (440-700 mm)
Nastro legs max height (760-1020 mm)



SIAT Spa

Via Puecher 22, 22078 Turate - Como
www.siat.com

100%
MADE in ITALY

SIAT S.p.A is recognised worldwide as a top-class machine manufacturer for secondary packaging and produces more than 17,000 machines per year, and has done since 1970. Our product range includes semi-automatic as well as fully automatic machines like Case Sealers and Case Erectors, Stretch Wrappers, Strapping Tools / Machines, Flexographic Printing Machines and Tape Dispensers. The company is present in more than 100 countries and is constantly investing worldwide to meet customers actual and future demands.